

TITLE

A further exploration of sensation seeking propensity, reward sensitivity, depression, anxiety, and the risky behaviour of young novice drivers in a structural equation model

AUTHORS AND AFFILIATIONS

Scott-Parker, B. ^{1,3}, Watson, B. ^{1,3}, King, M. J. ^{1,3}, & Hyde, M. K. ^{2,3}

¹ Centre for Accident Research and Road Safety – Queensland (CARRS-Q), Queensland University of Technology

² School of Psychology and Counselling, Queensland University of Technology

³ Institute of Health and Biomedical Innovation (IHBI), Queensland University of Technology

CORRESPONDING AUTHOR

Mrs Bridie Scott-Parker

CARRS-Q,

Queensland University of Technology,

K Block,

130 Victoria Park Road,

Kelvin Grove,

Queensland, 4059, Australia.

Telephone: + 61 7 3138 7727

Fax: + 61 7 3138 1111

Email: b.scott-parker@qut.edu.au

Abstract

Young novice drivers constitute a major public health concern due to the number of crashes in which they are involved, and the resultant injuries and fatalities. Previous research suggests psychological traits (reward sensitivity, sensation seeking propensity), and psychological states (anxiety, depression) influence their risky behaviour. The relationships between gender, anxiety, depression, reward sensitivity, sensation seeking propensity and risky driving are explored. Participants (390 intermediate drivers, 17-25 years) completed two online surveys at a six month interval. Surveys comprised sociodemographics, Brief Sensation Seeking Scale, Kessler's Psychological Distress Scale, an abridged Sensitivity to Reward Questionnaire, and risky driving behaviour was measured by the Behaviour of Young Novice Drivers Scale. Structural equation modelling revealed anxiety, reward sensitivity and sensation seeking propensity predicted risky driving. Gender was a moderator, with only reward sensitivity predicting risky driving for males. Future interventions which consider the role of rewards, sensation seeking, and mental health may contribute to improved road safety for younger and older road users alike.

Keywords

Sensation seeking propensity; reward sensitivity; depression; anxiety; gender; young driver

1. Introduction

1.1 The young novice driver

Novice drivers in motorised countries are typically the youngest drivers, and they have a disproportionately high rate of involvement in road crashes. This phenomenon has persisted throughout Australia even in the context of steadily-reducing crash rates for all drivers. To illustrate, Australian road fatalities among drivers aged 17-25 years represented 11.4 deaths per 100, 000 population in 1990. This almost halved to 6.3 deaths per 100, 000 population in 2009. In contrast, older drivers aged 40-59 years contributed 4.1 deaths per 100,000 population in 1990, reducing to 3.5 deaths per 100,000 population in 2009 (DITRDLG, 2010). Notwithstanding these improvements, persons aged 17-24 years comprised 13.0% of the licensed driving population in Queensland, Australia, in 2010; however, they represented 23.0% of the state's road toll (DTMR, 2011).

Young novices also place themselves at risk through their driving behaviour, including driving at night, driving on the weekend (Doherty et al., 1998), and exceeding speed limits (Yannis et al., 2007). A range of young novice driver attributes increase their risk of injury or death from a road crash. These include physiological characteristics (e.g. an underdeveloped brain; Steinberg, 2008); an underestimation of risks (Weinstein, 1980); and underdeveloped hazard perception skills (Lee et al., 2008). Young novices also have increased sensation seeking propensity (Jonah, 1997), and their driving behaviour is vulnerable to the influences of their friends and their parents (Scott-Parker et al., 2009a, under review). Of interest to the current research is the influence of the psychological states and traits of young novice drivers, specifically the increased risky driving associated with psychological distress, sensation seeking propensity and reward sensitivity (Scott-Parker et al., online).

1.2 *The psychosocial characteristics of the young novice driver*

To better understand the risky behaviour which contributes to the crash involvement and offences of young novice drivers, road safety researchers have begun to consider the nature and breadth of psychosocial characteristics including their personality traits. Risky behaviour is associated with the psychological distress of the young novice driver; with greater anxiety and depression being associated with more self-reported risky driving (Scott-Parker et al., 2011). Depression can also predict future drink driving in repeat-drink-driving offenders (Hubicka et al., 2010). Risky behaviour has been associated with sensation seeking propensity; greater sensation seeking propensity corresponding to more self-reported risky driving (e.g., Jonah, 1997; Scott-Parker et al., 2009a). Anxiety has also been associated with sensation seeking propensity and risky driving (Oltedal and Rundmo, 2006). Moreover, risky behaviour has also been associated with sensitivity to reward and sensitivity to punishment; greater reward sensitivity corresponding to more hazardous drinking (Loxton and Dawe, 2006) and self-reported risky driving (Scott-Parker et al., online); and individuals with greater sensitivity to reward and less sensitivity to punishment more likely to report marijuana use (Simons and Arens, 2007).

Scott-Parker et al. (online) first recognised the potential mediating relationships amongst the psychological states of anxiety and depression, and the trait of punishment sensitivity; and amongst the psychological traits of reward sensitivity and sensation seeking propensity. To illustrate, anxiety and depression have high comorbidity and are particularly prevalent during the adolescent period. Simulator-based research revealed that drivers with greater anxiety drive more cautiously (Stephens and Groeger, 2009), and individuals reporting more marijuana use also exhibit less sensitivity to punishment (Simons and Arens, 2007). Therefore the Authors suspected a mediation relationship amongst these traits and states. Similarly, the literature consistently reports more risky behaviour is

performed by those individuals with greater sensation seeking propensity and reward sensitivity, suggesting that the two constructs may be measuring the same construct, and accordingly the Authors suspected a mediation relationship amongst these states.

Scott-Parker et al. (online) explored the potential mediation relationships in greater detail using the Sensitivity to Punishment and Sensitivity to Reward Questionnaire (SPSRQ) (Torrubia et al., 2001), Kessler's Psychological Distress Scale (K10) (Kessler and Mroczek, 1994, cited in Andrews and Slade, 2001), the Impulsive Sensation Seeking Scale (ISSS) (Zuckerman et al., 1993), and the Behaviour of Young Novice Drivers Scale (BYNDS) (Scott-Parker et al., 2010). This was the first exploration of these mediating relationships, and the following relationships were found: sensitivity to punishment was found to be mediated by depression and anxiety; and reward sensitivity and sensation seeking propensity were found to be separate, yet related, constructs.

Accordingly a full path model which incorporated the co-varying depression and anxiety, and the co-varying reward sensitivity and sensation seeking propensity, was used to predict the self-reported risky behaviour of the young novice driver. Depression, reward sensitivity, sensation seeking propensity and anxiety explained a significant 24% of variance in the self-reported risky driving by the young novice driver. The important role of driver gender was also recognised in this research, and moderation analyses using the simplest approach of replicating the path model for each gender found that gender was a moderator: whilst depression, reward sensitivity, and sensation seeking propensity were influential for males, anxiety was also influential for females. Reward sensitivity was twice as influential for females as for males, whilst depression was twice as relevant for males as for females. Sensation seeking propensity exerted a similar influence for both genders. The path models explained 21% and 27% of variance in the risky driving behaviour of young male and female novice drivers, respectively.

The research of Scott-Parker et al. (online) was cross-sectional in nature, however. Considering the pervasive influence of the psychological traits/states of reward sensitivity, sensation seeking propensity, depression, and anxiety, longitudinal research is required to more fully understand their influence on self-reported risky driving. In addition, the stability of these constructs in the adolescent young novice driver merits further exploration.

1.3 Study aims

This study explores the self-reported risky driving behaviour of the young novice within the context of their reward sensitivity, sensation seeking propensity, depression, and anxiety in a longitudinal methodology. Previous research revealed the influence of these constructs is moderated by gender, and developmental considerations may be a factor. Accordingly a structural equation model based upon the research findings of Scott-Parker et al. (online) incorporating two sequential measures of reward sensitivity, sensation seeking propensity, depression, and anxiety is tested. Separate tests are conducted for each gender. The stability of reward sensitivity, sensation seeking propensity, depression, and anxiety is also examined, including separate gender analyses. Understanding the relationships between reward sensitivity, sensation seeking propensity, depression, and anxiety may reveal additional avenues for intervention in road safety, and in particular the longitudinal investigation may provide heretofore unrealised insights into the development and operationalisation of these constructs. The research does not, however, examine why the novice who is depressed and/or anxious drives in a different manner.

2. Method

2.1 Participants

Drivers ($n = 1170$, 461 males) aged 17-25 years ($M = 17.90$, $SD = 1.51$, Mode, Median = 17) volunteered to complete the 30-minute Learner Survey (Survey 1). Six months later, 390 of these novice drivers (113 males) aged 17-25 years ($M = 18.23$, $SD = 1.58$, Mode = 17, Median = 18) completed the 30-minute Provisional Survey (Survey 2). The analyses were conducted using the responses of these 390 participants only. The sample size exceeded the ratio of 20 participants to each variable required for structural equation modelling (Kline, 2011).

2.2 Measures

Participants reported age and gender, completed the binary 11-item abridged Sensitivity to Reward Questionnaire¹ (SRQ) (*yes, no*) (Time 1: skewness = .50, kurtosis = -.28; Time 2: skewness = .53, kurtosis = -.28), and responded to the 5-point Likert scales of the K10 (1 *none of the time* to 5 *all of the time*) which was subsequently divided into depression (K10-depression; Time 1: skewness = 1.34, kurtosis = -2.04; Time 2: skewness = 1.37, kurtosis = 1.69) and anxiety (K10-anxiety; Time 1: skewness = 1.20, kurtosis = 1.89; Time 2: skewness = 1.03, kurtosis = .74) subscales, and the 8-item Brief Sensation Seeking Scale (BSSS)² (Hoyle et al., 2002) (1 *strongly disagree* to 5 *strongly agree*) (Time 1: skewness = .02, kurtosis = -.40; Time 2: skewness = -.04, kurtosis = .12). Both surveys incorporated the 44-item Behaviour of Young Novice Drivers Scale (BYNDS) (Scott-Parker et al., 2010) (1 *never* to 5 *almost always*) (Time 2: skewness = .96, kurtosis = 1.19). Items in scales were summed and analyses used composite scores for each instrument. Higher SRQ, BSSS, and K10 scores indicate greater reward sensitivity, sensation seeking propensity, anxiety and depression respectively; higher BYNDS scores indicate more self-reported risky driving.

2.3 Procedure and design

Surveys were cross-sectional; however the data in the longitudinal project comprised repeated measures. Every Learner driver in Queensland, Australia, who passed their practical driving assessment 1 April through 30 June 2010 was invited to participate. Incentives were the chance to win petrol vouchers (Survey 1 and 2), and movie tickets (Survey 2). The overall response rate for Survey 1 was 14.4% ($n = 1333$, 9 393 reminder letters were mailed to novices of all ages). The response rate for novices aged 17-25 years could not be calculated due to privacy restrictions preventing access to the ages of novices who did not participate. There was 66.7% attrition; however both surveys were representative of the Queensland population: 62.2% of the Survey 2 participants resided in major cities and 1.6% resided in remote regions, and 60.0% of Queensland's population resided in major cities and 2.0% resided in remote regions (ABS, 2010).

2.4 Statistical analyses

Measures of internal consistency utilised Cronbach's alpha (α). Bivariate correlations explored the strength of associations between study variables. Means were compared using analysis of variance (ANOVA) and paired t-tests. The online survey was created in KeySurvey Enterprise Online Survey Software. Analyses were conducted using AMOS and PASW version 18.0.

3. Results

3.1 Descriptive analyses, comparison of means

The Learner (herein 'Time 1') drivers reported moderate levels of sensation seeking propensity (BSSS range 8-40), reward sensitivity (SRQ range 0-11), depression (K10-depression range 6-30), and anxiety (K10-anxiety range 4-20) (Table 1). The Provisional (herein 'Time 2') drivers reported moderate levels of risky driving (BYNDS range = 44-134), sensation seeking

propensity (BSSS range 8-40), reward sensitivity (SRQ range 0-11), depression (K10-depression range 6-27), and anxiety (K10-anxiety range 4-16). There were no significant differences in depression and anxiety between the two times (average period six months). There was a significant difference for sensation seeking propensity ($p < .01$) and reward sensitivity ($p < .001$), with Time 2 drivers reporting greater sensation seeking propensity and lower reward sensitivity.

[Insert Table 1 here]

Males reported greater reward sensitivity and sensation seeking propensity, whilst females reported more depression and anxiety at each time (Table 1). There was a significant gender difference for anxiety, Time 1 males ($p < .01$) and Time 2 males ($p < .05$) reported significantly less anxiety than Time 1 and Time 2 females. ANOVA also revealed a significant difference for sensation seeking propensity and reward sensitivity, with Time 1 ($p < .001$, $p < .01$ respectively) and Time 2 males ($p < .01$, $p < .001$) reporting significantly greater sensation seeking propensity and reward sensitivity. There were no significant differences on any of the measures of males for the two time points. For females there was a significant difference in sensation seeking propensity ($p < .01$) and reward sensitivity ($p < .001$), Time 1 females reporting lower sensation seeking propensity and greater reward sensitivity than Time 2 females. Differences in depression and anxiety between each time point were non-significant.

Reward sensitivity was strongly associated with sensation seeking propensity (higher reward sensitivity associated with higher sensation seeking propensity at Time 1 and Time 2), and reward sensitivity and sensation seeking propensity (both time points) were strongly associated with more self-reported risky driving behaviour (Table 2). Greater depression was associated with greater anxiety

at both time points. Provisional anxiety and depression were moderately associated with greater self-reported risky driving behaviour, whilst the relationship between Time 1 anxiety and depression and risky driving was significant but weak.

[Insert Table 2 here]

For female young novice drivers Time 1 reward sensitivity and Time 2 reward sensitivity were positively associated with Time 2 depression; and Time 2 sensation seeking propensity was associated with Time 2 anxiety and Time 2 depression. For males, Time 1 anxiety and Time 1 depression were significantly associated with Time 2 sensation seeking propensity. In addition, whilst significant for both genders, the positive relationship between reward sensitivity and sensation seeking propensity at both times, and risky driving (BYNDS), was stronger for females than males. Figure 1 depicts the correlations coefficients for which the genders differ by $\geq .10$.

[Insert Figure 1 here]

3.2 *Structural equation modelling*

The variables demonstrated univariate (Table 1) and multivariate normality (skew < 2 , kurtosis < 7), therefore structural equation modelling (SEM) used maximum likelihood estimation to estimate the parameters of the model. Good model fit was determined by a combination of likelihood ratio chi-square statistic (χ^2 non-significant or < 3 times the degrees of freedom), Bentler's Comparative Fit Index (CFI $\geq .95$), the Steiger-Lind Root Mean Square Error of Approximation (RMSEA $\leq .08$) including 90% confidence intervals (Kline, 2011), the Tucker-Lewis Index (TLI $\geq .95$). The cross-sectional path diagram of Scott-Parker et al. (online) was the base model, and Time 1 and Time 2 variables were integrated (Figure 2).

[Insert Figure 2 here]

Time 1 variables were presumed to inform corresponding Time 2 variables, the Time 2 variables predicting the intermediate drivers' risky behaviour. This model was a good fit, $\chi^2(18, N = 390) = 49.52, p < .01$, CFI = .98, TLI = .96, RMSEA = .06 [.04-.08] and explained 24% of variance in self-reported risky driving (Figure 2). Structural paths significant at $p < .05$ were positive and revealed risky driving was predicted by the Time 2 driver's sensation seeking propensity, reward sensitivity, and anxiety, with greater sensation seeking propensity, reward sensitivity and anxiety associated with more risky driving.

3.2.1 Moderation analyses

The separate gender analyses revealed interesting differences in the contribution of the model variables to self-reported risky driving (Figure 3). The model for males had a good fit to the data, $\chi^2(22, N = 113) = 30.57, p = .11$, CFI = .98, TLI = .96, RMSEA = .06 [.00- .11] and explained 27% of variance. The only significant predictor was SR, with greater SR associated with more risky driving behaviour. The model for the female young novice drivers was also a good fit, $\chi^2(22, N = 277) = 54.95, p < .001$, CFI = .96, TLI = .94, RMSEA = .07 [.05-.10] and explained 23% of variance. The significant predictors were PPSS, SR, and ANX, with greater PPSS, SR, and ANX associated with more risky driving behaviour.

[Insert Figure 3 here]

4. Discussion

A longitudinal exploration of the stability of reward sensitivity, sensation seeking propensity, anxiety and depression as indicated by the scores obtained on the Abridged SRQ, the BSSS, and the K10 provided important insights into the psyche of the developing novice driver. Interestingly the experienced of the psychological states of depression and anxiety remained relatively

stable throughout this time, further evidenced by the correlations between the Time 1 and Time 2 measures. In contrast, psychological traits – also correlated between the Time 1 and 2 measures, and frequently presumed to be stable – appeared to change over the follow-up period, with the novice drivers becoming significantly less sensitive to rewards and exhibiting significantly greater sensation seeking propensity over this time. Whilst such fluctuation may be due to psychosocial and physiological maturation of the adolescent novice driver, further research is required to determine the causes and moderators of this instability. In particular the application of psychosocial theory may prove informative.

This finding is of particular concern to road safety researchers, because the Provisional driver is able to drive unsupervised and may drive in a manner that may be motivated by their sensation seeking propensity. Females reported significantly greater anxiety and significantly less reward sensitivity and sensation seeking propensity than males at both measurement intervals which may be reflected in lower rates of risky driving reported by females. The revised longitudinal model also explained substantial variance in each of the constructs except for depression, and it is unclear at this time why. As expected, there were clear relationships between the Learner psychosocial constructs and the comparable Provisional psychosocial constructs, and the quantification of these relationships through the present longitudinal research is also informative. To illustrate, an increase of 1 *SD* in Learner reward sensitivity would predict an increase of .6 *SD* in Provisional reward sensitivity.

The non-contribution of depression in the current research requires further reflection, particularly when these findings are in stark contrast to that of Scott-Parker et al. (online). Both the Time 1 and Time 2 drivers in Study 2 reported lower depression than those in the prior research ($M = 11.84$, $SD = 4.86$). Scott-Parker et al. also reported significant correlations between depression and

gender, depression and reward sensitivity, and depression and sensation seeking propensity; however these findings were not replicated in the current research. In addition, anxiety levels of participants in the current research were also lower than that of the earlier research ($M = 7.63$, $SD = 2.69$). Interestingly the same gender patterns emerge in each study, with females consistently reporting greater anxiety and depression. Whilst the differences in the research findings between the two studies may be due to selection bias, the findings may instead suggest that young tertiary students in Queensland experience greater depression and anxiety which may have implications for tertiary education providers who need to be aware their students may be at greater risk of mental health difficulties. Tertiary students were also riskier drivers than the general young novice driver population ($M = 84.67$, $SD = 20.44$; Scott-Parker et al., online), reinforcing the need for targeted interventions.

The results have implications for mental health practitioners, medical professionals, and road safety researchers alike. Psychological distress is a predictor of risky driving, and the longitudinal research has begun to elucidate the separate influence(s) of depression and anxiety. Young novice drivers, and females in particular, who are experiencing anxiety are at increased risk of injury from a car crash. In addition, depression was also found to place the young female novice driver at greater risk. Mental health practitioners counselling young persons experiencing anxiety and depression who have a driver's licence should be aware of the increased risk of injury on the road. Medical professionals treating young persons with a driver's licence who have been injured through engagement in risky behaviour – including risky driving – should be aware the novice may also be experiencing mental health issues. Interventions designed to ameliorate depression and anxiety are likely to have broader benefits, such as improved road safety for young and older road users alike. Further research is required, however, to provide an understanding of *why* the depressed and/or

anxious novice drives in a different, more risky, manner, and this can also inform the development and evaluation of mental health and road safety countermeasures.

Furthermore, the young persons' sensation seeking propensity and reward sensitivity may have contributed to their participating in the risky behaviour, including risky driving. Interventions designed to counter risky behaviour by young novice drivers – such as the graduated driver licensing legislation introduced in Queensland in July 2007 – frequently rely upon the threat and administration of punitive measures to curtail such behaviour. However this study suggests that the risky driving of the young novice driver was influenced by their sensation seeking propensity and reward sensitivity. Therefore an intervention that takes into account young drivers' sensation seeking propensity and reward sensitivity may be more effective in reducing risky behaviour. In addition, rather than generic interventions, gender-specific programs which also consider the separate influences of anxiety, depression, sensation seeking propensity and reward sensitivity could be more efficacious in reducing risky driving.

This was the second study to explore the link between anxiety, depression, sensation seeking propensity and reward sensitivity in relation to the self-reported risky behaviour of young novice drivers, and the first to incorporate a longitudinal methodology. SEM for each gender suggested that the nature of the influence of these psychosocial constructs is not straightforward. Not only should research examining the breadth and depth of various influences upon young novice driver behaviour incorporate separate analyses by gender, but interventions similarly may need to consider the gender of the young novice driver. In addition, the study again divided the nature of psychological distress as measured by the K10 according to the separate subscales of anxiety and depression. This allowed a further delineation of the influence of these mental health variables that have been found to be predictive of risky driving behaviour.

Online research methods are advantageous because they are inexpensive, easy to use, and able to reach a large audience in a short time period (Huang, 2006). Also, young persons are more likely to be computer-literate and able to complete the simple online instrument (Knapp and Kirk, 2003). More females than males participated in each survey (52.0% of Queensland Learners were female), and therefore separate gender analyses were undertaken. Further, the novice drivers – and male novice drivers in particular – who chose not to participate in the longitudinal research may have been more risky drivers. The overall response rate was relatively low, and a greater proportion of Learners aged 17 years chose to participate (58.2% of the participants compared to 49.8% of Queensland's Learner population). The attrition between the two samples appears high for a follow-up survey done within a comparatively short period (six months); however 99% of Queensland was declared a disaster-zone after an exceptionally wet and windy summer (widespread flooding, cyclones) during the follow-up period (AAP, 2011). Notwithstanding the attrition and the potential introduction of biases, the sample geographically-represented the population distribution of Queensland.

This longitudinal research has allowed an exploration of the stability not only of anxiety, depression, sensation seeking propensity and reward sensitivity; but also the extent of the influence of these states and traits upon the behaviour of the young novice driver as they mature from an inexperienced novice driver to a novice with six months independent driving experience. Longitudinal research over an extended period and with a larger sample could further explore the relationships between and amongst the variables and risky driving, and the findings could be used to inform intervention development. In particular, actual driving behaviour captured via in-car recording devices or in a driving simulator, insurance-reported crashes and police-detected offences could also be incorporated in different novice driving populations in Australia and around the world. The apparent instability of the psychological

traits of sensation seeking propensity and reward sensitivity should also be examined, to determine whether it reflects underlying changes in the traits or is simply a product of inadequate measurement.

In recent years, research into young novice road safety has begun to consider the psychosocial influences upon their risky driving which contributes to their persistent overrepresentation in crashes, injuries and fatalities. The relationship between anxiety, depression, sensation seeking propensity and reward sensitivity within the domain of the risky driving of the young novice had not been considered in a longitudinal methodology, and the stability of these constructs over a six month period was considered separately for each gender. Whilst the young novice's reward sensitivity, sensation seeking propensity, and anxiety explained their risky driving behaviour, sensation seeking propensity was twice as influential, and reward sensitivity almost three times as influential, as anxiety. Whilst the influence of these variables differed considerably for males and females, it is noteworthy that the small sample of males suggests that these findings are preliminary. The larger sample of females indicates that reward sensitivity is almost as influential as sensation seeking propensity which is twice as influential as anxiety. Interventions that attempt to reduce rewards for risky driving, discourage the expression of sensation seeking propensity, and address psychological distress merit further consideration. Furthermore, attention to the gender differences in the influence of these psychosocial constructs is likely to result in more effective interventions.

Acknowledgements

Special thanks to the Queensland Department of Transport and Main Roads (formerly Queensland Transport) for their assistance in the recruitment of novice drivers for the second study. The first author is the recipient of a National Health and Medical Research Council Postgraduate Research Scholarship.

Footnotes

¹ In the interests of brevity and to address psychometric problems such as low factor loadings (e.g., Li et al., 2007) identified in applications of the SPSRQ, preliminary research refined an abridged version of the Sensitivity to Reward Questionnaire. Three separate exploratory factor analyses which retained only items loading above .40 for all three groups were conducted: the total sample, the male participants only, and the female participants only. The participants were 476 drivers (238 males) aged 17-25 years ($M = 19.0$, $SD = 1.59$) with a Provisional licence who attended 1 of the 13 major tertiary institutions across Queensland; matched for age, gender and tertiary institution. The Abridged SRQ correlated very highly with the original SRQ ($r = .90$).

² In the preliminary research, the predictive ability of the BSSS and the ISSS were also compared through hierarchical multiple regressions which alternated the steps in which each scale was entered into the equations. In the interests of brevity, and as the scales were highly correlated ($r = .84$) and accounted for almost the same amount of variance in self-reported risky driving (BSSS $\Delta R^2 = .152$, ISSS $\Delta R^2 = .166$), the shorter BSSS was incorporated in the larger research project.

References

- AAP., 2011. Queensland 99 per cent disaster-declared as flooded north faces new cyclone threat. *The Courier Mail*, 11 March 2011.
- ABS., 2010. National regional profile. Australian Bureau of Statistics: Canberra.
- Andrews, G., Slade, T. 2001. Interpreting scores on the Kessler Psychological Distress Scale (K10). *Australia and New Zealand Journal of Public Health* 25 (6), 494-497.
- DTMR., 2011. Queensland Road Toll 2010. Queensland Government, Brisbane.
- DITRDLG., 2010. Road deaths Australia. 2009 Statistical Summary. Canberra: Department of Infrastructure, Transport, Regional Development and Local Government.
- Doherty, S.T., Andrey, J.C., MacGregor, C., 1998. The situational risks of young drivers: The influence of passengers, time of day and day of week on accident rates. *Accident Analysis and Prevention* 30, 45-52.
- Hoyle, R.H., Stephenson, M.T., Palmgreen, P., Lorch, E.P., Donohew, R.L., 2002. Reliability and validity of a brief measure of sensation seeking. *Personality and Individual Differences* 32, 401-414.
- Huang, H.M., 2006. Do print and web surveys provide the same results? *Computers in Human Behavior* 22, 334-350.
- Hubicka, B., Kallmen, A., Hiltunen, A., Bergman, H., 2010. Psychological distress and its correlates in Chinese adolescents. *Australian & New Zealand Journal of Psychiatry* 43, 674-681.
- Jonah, B.A., 1997. Sensation seeking and risky driving: A review and synthesis of the literature. *Accident Analysis and Prevention* 29, 651-665.

- Kline, R., 2011. Principles and practice of structural equation modelling (3rd ed.). London: The Guilford Press.
- Knapp, H., Kirk, S.A., 2003. Using pencil and paper, internet and touch-tone phones for self-administered surveys: Does methodology matter? *Computer in Human Behavior* 19, 117-134.
- Lee, S.E., Klauer, S.G., Olsen, E.C.B., Simons-Morton, B.G., Dingus, T.A., Ramsey, D.J., et al. 2008. Detection of road hazards by novice teen and experienced adult drivers. *Transportation Research Record* 2078, 26-32.
- Li, C.S.R., Huang, C.Y., Lin, W.Y., Sun, C.W.V., 2007. Gender differences in punishment and reward sensitivity in a sample of Taiwanese college students. *Personality and Individual Differences* 43, 475-483.
- Loxton, N.J., Dawe, S., 2006. Reward and punishment sensitivity in dysfunctional eating and hazardous drinking women: Associations with family risk. *Appetite* 47, 361-371.
- Oltedal, S., Rundmo, T., 2006. The effects of personality and gender on risky driving behaviour and accident involvement. *Safety Science* 44, 621-628.
- Palmgreen, P., Donohew, L., Lorch, E.P., Hoyle, R.H., Stephenson, M.T., 2001. Television campaigns and adolescent marijuana use: Tests of sensation seeking targeting. *American Journal of Public Health* 91, 292-295.
- Scott-Parker, B., Watson, B., King, M.J., 2009. Understanding the influence of parents and peers upon the risky behaviour of young drivers. *Transportation Research Part F* 12, 470-482.
- Scott-Parker, B., Watson, B., King, M.J., 2010. The risky behaviour of young drivers: Developing a measurement tool. Proceedings of the 24th Canadian Multidisciplinary Road Safety Conference, Niagara Falls, Canada, June 6-9, 2010.

Scott-Parker, B., Watson, B., King, M.J., Hyde, M.K., 2011. The psychological distress of the young novice driver: A brief report. *Injury Prevention* 17 (4), 275-277.

Scott-Parker, B., Watson, B., King, M.J., Hyde, M.K., online. The influence of sensitivity to reward and punishment, propensity for sensation seeking, depression and anxiety on the risky behaviour of novice drivers: A path model. *British Journal of Psychology*.

Scott-Parker, B., Watson, B., King, M.J., Hyde, M.K., under review. "They're lunatics on the road": Exploring the normative influences of parents, friends, and police on young novice's risky driving decisions. *Safety Science*.

Simons, J.S., Arens, A.M., 2007. Moderating effects of sensitivity to punishment and sensitivity to reward on associations between marijuana effect expectancies and use. *Psychology of Addictive Behaviors* 21 (3), 409-414.

Steinberg, L., 2008. A social neuroscience perspective on adolescent risk-taking. *Developmental Review* 28, 78-106.

Stephens, A.N., Groeger, J.A., 2009. Situational specificity of trait influences on drivers' evaluations and driving behaviour. *Transportation Research Part F* 12, 29-39.

Torrubia, R., Avila, C., Molto, J., Caseras, X., 2001. The Sensitivity to Punishment and Sensitivity to Reward Questionnaire (SPSRQ) as a measure of Gray's anxiety and impulsivity dimensions. *Personality and Individual Differences* 31, 837-862.

Weinstein, N.D., 1980. Unrealistic optimism about future life events. *Journal of Personality and Social Psychology* 39 (5), 806-820.

Yannis, G., Papadimitriou, E., Antoniou, C., 2007. Impact of enforcement on traffic accidents and fatalities: A multivariate multilevel analysis. *Safety Science* 46 (5), 738-750.

Zuckerman, M., Kuhlman, D.M., Joireman, J., Teta, P., Kraft, M., 1993. A comparison of three structural models for personality: The big three, the big five, and the alternative five. *Journal of Personality and Social Psychology* 65 (4), 757-768.

Table 1

Time 1 and Time 2 measures (N = 390), including for males (N = 113) and females (N = 277)

Scale	Time 1								Time 2							
	α	Males				Females				α	Males			Females		
		<i>M</i>	<i>SD</i>	<i>M</i>	<i>SD</i>	<i>M</i>	<i>SD</i>	<i>M</i>	<i>SD</i>		<i>M</i>	<i>SD</i>	<i>M</i>	<i>SD</i>		
SRQ	.72	3.8	2.7	<i>4.4</i>	<i>2.7</i>	3.6	2.5	.73	3.4	2.4	<i>4.1</i>	<i>2.6</i>	3.1	2.2		
BSSS	.83	22.0	6.5	<i>23.8</i>	<i>6.5</i>	21.2	6.3	.80	22.8	6.6	<i>24.4</i>	<i>6.5</i>	22.1	6.6		
ANX	.77	<i>7.2</i>	<i>2.6</i>	<i>6.6</i>	<i>2.6</i>	<i>7.4</i>	<i>2.5</i>	.75	<i>7.0</i>	<i>2.7</i>	<i>6.5</i>	<i>2.3</i>	<i>7.2</i>	<i>2.8</i>		
DEP	.89	<i>10.4</i>	<i>4.1</i>	<i>9.9</i>	<i>4.1</i>	<i>10.6</i>	<i>4.1</i>	.87	<i>10.4</i>	<i>4.4</i>	<i>9.7</i>	<i>3.9</i>	<i>10.6</i>	<i>4.5</i>		
BYNDS	–	–	–	–	–	–	–	.88	<i>75.9</i>	<i>15.0</i>	<i>77.5</i>	<i>16.6</i>	<i>75.2</i>	<i>14.3</i>		

α = Cronbach's Alpha; – = Not Applicable. Bold font indicates significant differences between surveys measured by paired-sample t-tests. Italic font indicates significant differences between genders measured by ANOVA. SRQ = Abridged Sensitivity to Reward Questionnaire; BSSS = Brief Sensation Seeking Scale; DEP = Depression subscale of Kessler's Psychological Distress Scale; ANX = Anxiety subscale of Kessler's Psychological Distress Scale; BYNDS = Behaviour of Young Novice Drivers Scale.

Table 2

Correlations between gender, psychological constructs, and risky driving

Key	Gender	T1	T1	T1	T1	T2	T2	T2	T2	T2
Measure		SR	PPSS	ANX	DEP	SR	PPSS	ANX	DEP	BYNDS
Gender	—									
T1 SR	-.15**	—								
T1 PPSS	-.18***	.42***	—							
T1 ANX	.13**	.21***	.14**	—						
T1 DEP	.07	.22***	.10	.61***	—					
T2 SR	-.20***	.65***	.40***	.21***	.19***	—				
T2 PPSS	-.16**	.33***	.64***	.11*	.10	.49***	—			
T2 ANX	.12*	.18**	.16**	.49***	.38***	.15**	.15**	—		
T2 DEP	.10	.12*	.05	.32***	.52***	.08	.08	.59***	—	
T2 BYNDS	-.07	.30***	.37***	.15**	.13**	.44***	.40***	.24***	.21***	—

Note: * $p < .05$, ** $p < .01$, *** $p < .001$. T1 = Time 1; T2 = Time 2. Bivariate correlations between continuous variables utilised Pearson's product moment correlation (r). Bivariate correlations between continuous and dichotomous variables utilised point biserial correlations (r_{pb}). See Table 1 for construct definitions.

Figure 1

Correlations between psychological constructs and risky driving behaviours according to gender
(for correlations where the difference in the correlation coefficients between the genders is $\geq .10$)

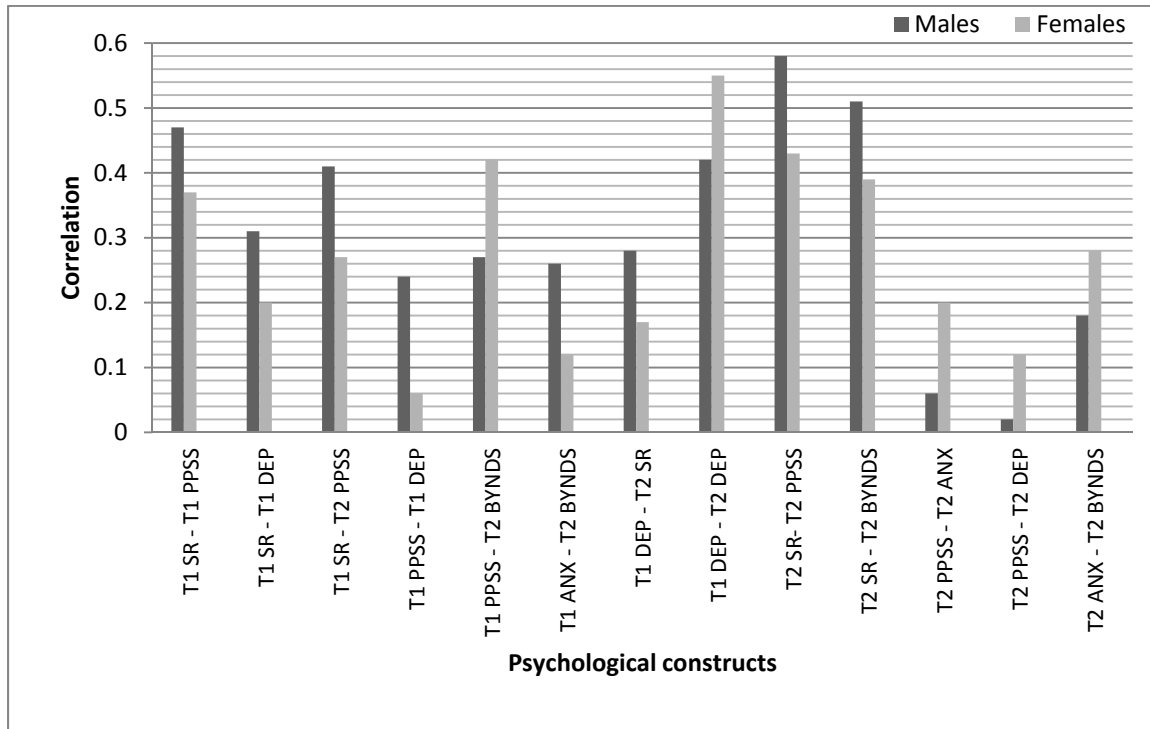
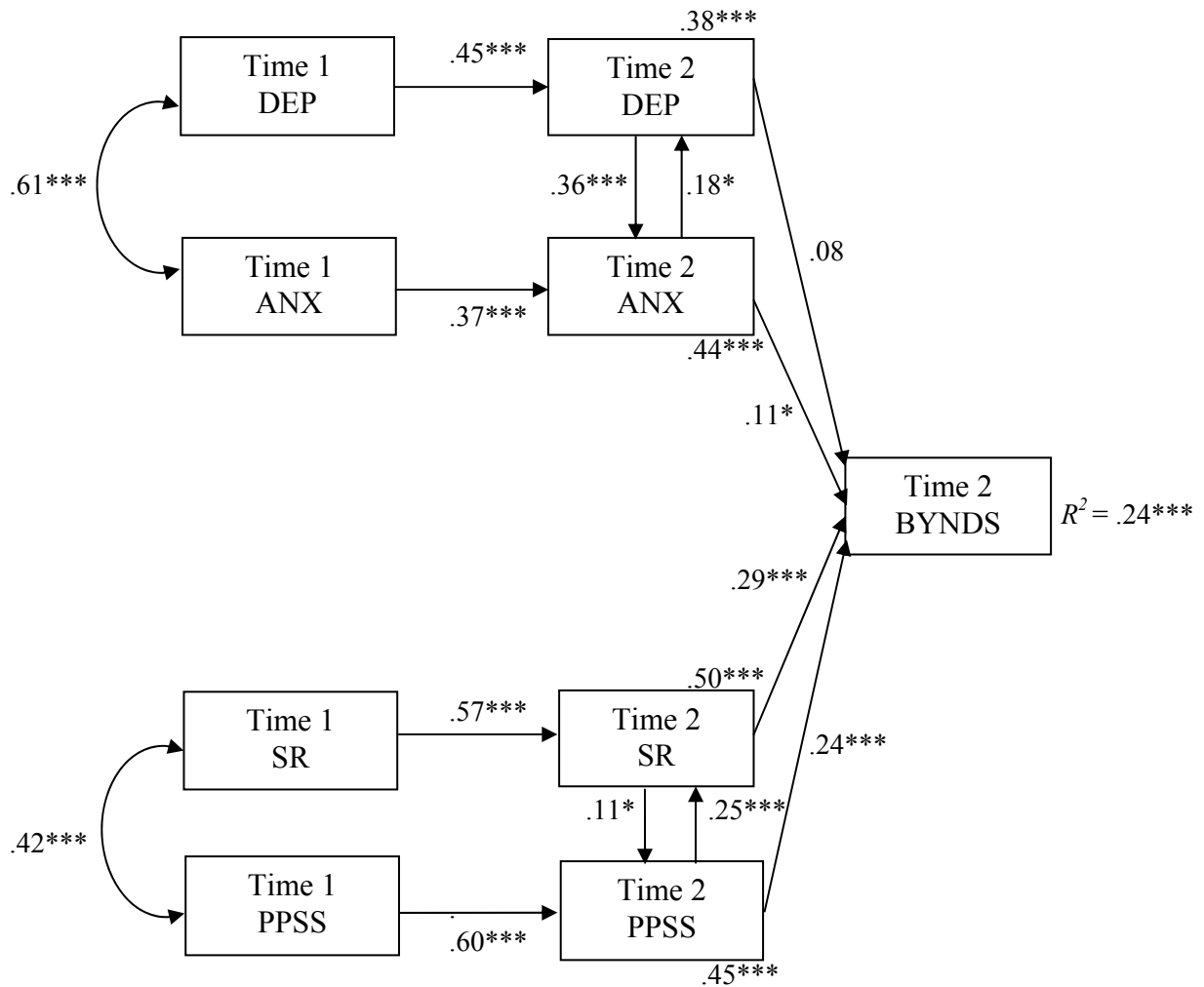

Figure 2

The longitudinal structural equation model for reward sensitivity, anxiety and depression, sensation seeking propensity and self-reported risky driving



Note: * $p < .05$, *** $p < .001$. See Table 1 for construct definitions.

Figure 3

Structural equation models illustrating the moderation by gender of the self-reported risky driving behaviour of young novice drivers (male coefficients shown in bold italic font)

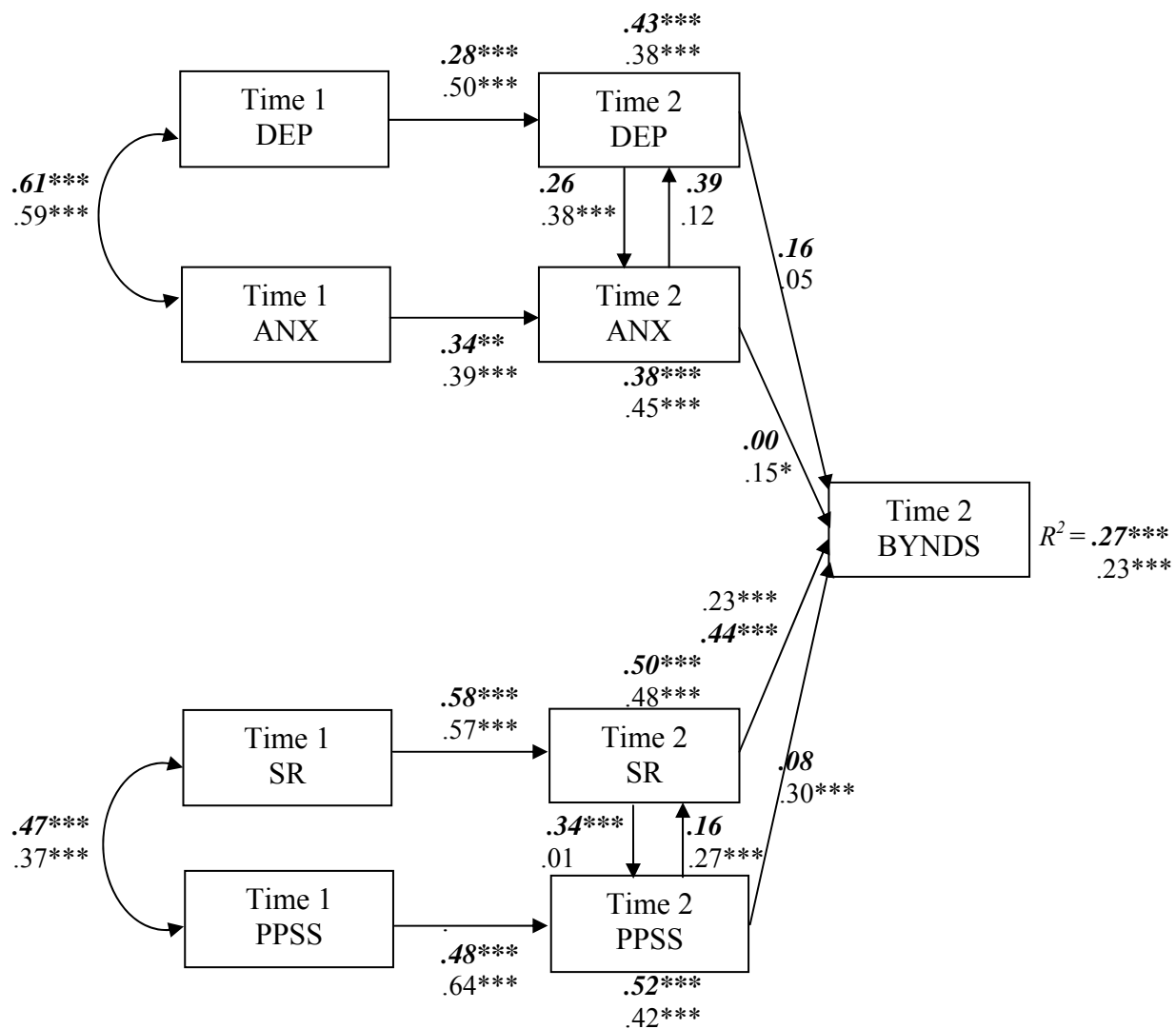

Note: * $p < .05$, *** $p < .001$. See Table 1 for construct definitions.